

# DCM-270BAH-OS

Item # \_\_\_\_\_

Project: \_\_\_\_\_

Qty: \_\_\_\_\_

\*AutoCad available on KCL

## OPTI-SERVE SERIES SANITARY CUBELET ICE MACHINE/DISPENSER

DCM-270BAH-OS

11/10

Item # 13159

### DIMENSIONS W x D x H

#### DCM-270BAH-OS

16<sup>9/16</sup> x 24<sup>1/8</sup> x 31<sup>11/16</sup>\*  
\*with 4" legs

#### SD-270

16<sup>1/2</sup> x 24 x 35<sup>3/16</sup>

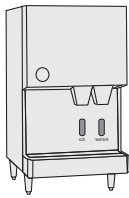

DCM-270



SD-270  
optional  
stand

### DCM-270BAH-OS

Air-Cooled  
Shown on an optional  
**SD-270 Stand**



\*Transparent drinkware may affect dispensing operations.  
SD-270 door is reversible.

### DCM-270BAH-OS

- CleanCycle 12®: Every 12 hours, unit performs 15 minute purge to rid itself of impurities
- LED Remote sensor for hands-free operation
- Sealed LED housing prevents moisture from entering, eliminating the possibility of an electrical short
- Durable stainless steel exterior
- Up to 288 lbs. of ice production per 24 hours
- Easy to chew, cubelet ice
- Self contained design reducing opportunities for cross contamination
- Dispenses ice and water
- Removable air filter
- Stainless steel internal auger
- R-404A Refrigerant
- Protected by HoshiGuard Antimicrobial Agent **HOSHIGUARD**



### SD-270 Stand

- Heavy duty stand for floor model icemaker/dispenser
- Corrosion resistant stainless steel exterior
- Easy cleaning with attractive appearance
- Locking, reversible door

### Warranty

Valid in United States, Canada, Puerto Rico, & U.S. Territories. Contact factory for warranty in other countries.

**Three Year** - Parts & Labor on entire machine. (Serial numbers VxxxxxJ and after.)

**Five Year** - Parts on: hermetic compressor, air-cooled fin and tube type condenser.



ISO9001-15014:2001



# DCM-270BAH-OS SANITARY CUBELET ICE MACHINE/DISPENSER OPTI-SERVE SERIES

## DIMENSIONS W x D x H

**DCM-270BAH-OS**  
16<sup>9</sup>/<sub>16</sub> x 24<sup>3</sup>/<sub>16</sub> x 31<sup>7</sup>/<sub>8</sub>"  
\*with 4" legs  
**SD-270**  
16<sup>1</sup>/<sub>2</sub> x 24 x 35<sup>3</sup>/<sub>16</sub>"

- Hands-free ice and water dispenser
- Optional stand with locking door

## AIR-COOLED

Water Temp ° F.	50°	70°	90°	
Air Temp ° F.	70°	288	276	265
80°	254	243	233	
90°	224	220	205	

## UTILITY CONSUMPTION

Model Number	KWH per 100 LBS.		GAL per 100 LBS.	
	90/70	70/50	90/70	70/50
DCM-270BAH-OS	7.3	5.3	12.0	12.0

## SPECIFICATIONS

Model Number	Condenser	Amperage	Shipping Weight
DCM-270BAH-OS	Air-Cooled	8.5	166 lbs.
SD-270	N/A	N/A	89 lbs.

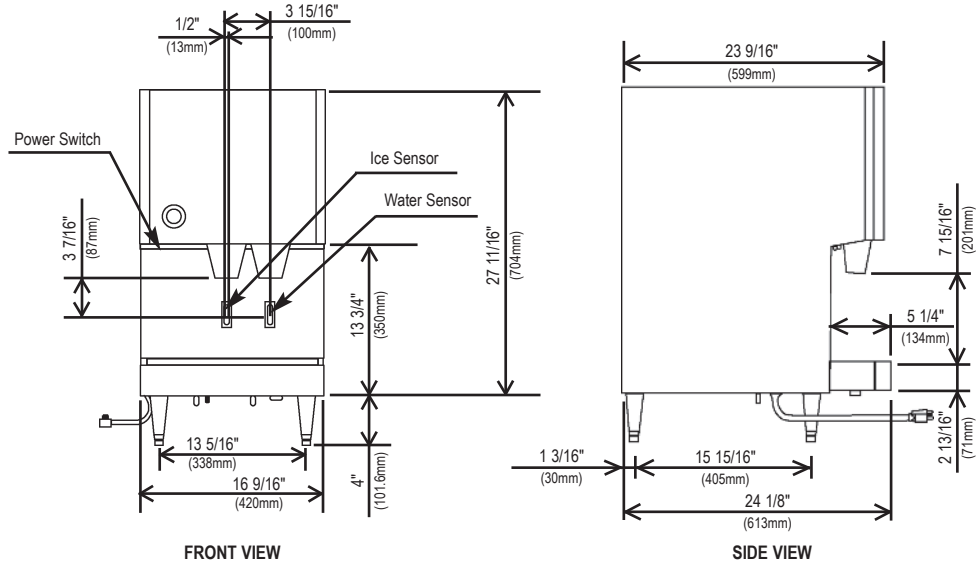

- Separate ICE and WATER Dispensing
- LED Remote Sensor for hands-free operation.

Flaked ice compacted into cubelets by extruding head cutter and stored in an insulated bin with continuous agitation during dispensing and direct dispensing auger

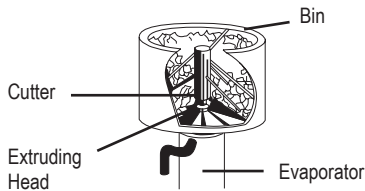

- Circuit breaker or fuse protects gear motor from overload.
- Gear motor runs one minute after termination of ice making to clear all ice from evaporator.

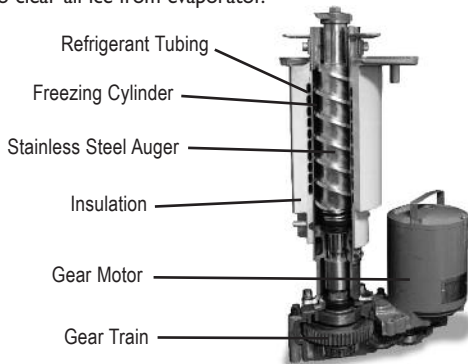

EVAPORATOR

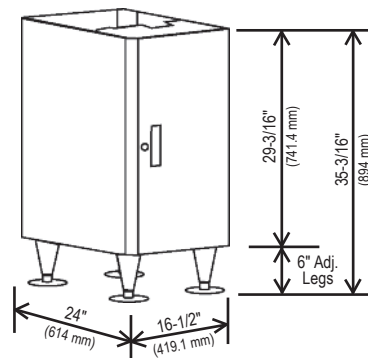

SD-270

## ELECTRICAL & PLUMBING/DCM-270BAH-OS

- 115V/60/1
- 15 amp cord connection



ISO 9001 • ISO 14001

© HOSHIZAKI AMERICA, INC.

618 Hwy. 74 S., Peachtree City, GA 30269

## OPERATING LIMITS

- Ambient Temp Range 45 - 100°F
- Water Temp Range 45 - 90°F
- Water Pressure 10 - 113psig
- Voltage Range 104 - 127V

## SERVICE

- Panels easily removed and all components accessible for service.
- Removable/cleanable air filter.

